

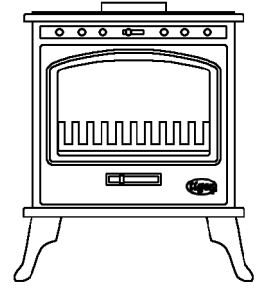

TIGER PLUS

CAST-IRON MULTI-FUEL STOVE

INSTALLATION AND OPERATING INSTRUCTIONS



LEAVE THIS DOCUMENT WITH THE HOUSEHOLDER !

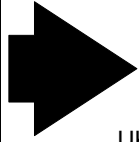

THE INSTALLATION AND SERVICING OF THIS APPLIANCE MUST BE SUPERVISED BY A QUALIFIED SOLID FUEL ENGINEER. THE SUPPLIERS WILL ACCEPT NO RESPONSIBILITY WHATEVER FOR APPLIANCES NOT SO INSTALLED.

A register of qualified engineers is available from:

UK: The Solid Fuel Association, 7 Swanwick Court Alfreton Derbyshire DE55 7AS Tel:0845-601-4406 www.solidfuel.co.uk
 RoI: Irish Nationwide Fireplace Organisation, 162 Capel Street, Dublin 1 Tel:01-801-5959 www.fireplace.ie

THIS APPLIANCE BECOMES EXTREMELY HOT AND CAN PRODUCE POISONOUS GASES.

A fire-guard should be used if children or the infirm are present. The installer is required to EXACTLY follow these instructions and to completely comply with all local, national and international standards.

This document is a guide to installing and using the Tiger Plus stove, any national or local regulations must be complied with. Building regulations for the UK, RoI and IoM can be found at

www.tiger-stoves.com

ASBESTOS: Tiger does not contain asbestos, but you should be careful to avoid disturbing any asbestos when removing an old installation.

FIRE CEMENT is caustic - wash your hands thoroughly after using it.

WEIGHT Protect your spine by moving the stove only with assistance.

FUME EMISSION: Properly installed and operated this appliance will not emit fumes into the dwelling. Occasional fumes from de-ashing and refuelling may occur. However, persistent fume emission is potentially dangerous and must not be tolerated. If fume emission persists, then the following immediate action should be taken:

(a) open doors and windows to ventilate the room. (b) let the fire go out or eject and safely dispose of fuel from the appliance. (c) check the flue or chimney for blockage and clean if required. (d) do not attempt to re-light the fire until the cause of the fume emission has been identified and corrected. If necessary seek expert advice

HEAT: The surfaces of the appliance and the attached fluepipe will become *extremely* hot- a fireguard should be used if children or the infirm are present. Flammable materials (including fuel) should not be stored near to the appliance. If the Europa Hi-Leg unit is fitted and used as a log store, logs must not be placed higher than the central 'bridging' member.

Conforms to EN13240

Independently tested by SGS
 Arnheim, 2007
 Approved Laboratory No 0608



Fuel	Wood (Beech)	Mineral Fuel (Ancit)
Efficiency	77.90%	70.30%
Max. Output	6.2kW	6.2kW
CO Emission (as if at 13% O2)	0.27%vol	0.13%vol
Mean Flue Temperature	313° C	286° C
Clearance to combustibles	Rear 40cm Sides 30cm	Rear 40cm Sides 30cm
Smoke Emission	77 mg/m ³	95 mg/m ³
Gas flow	5.4 g/sec	6.3 g/sec
Flue Draught	Min 12Pa	Min 12Pa

BEFORE YOU BEGIN...

CHIMNEY Your chimney creates the draught which Tiger needs in order to work - it must:

- Conform to local building regulations.
- Be at least 5m high.
- Terminate at least 1m above any roof ridge.
- Have an internal cross-section not less than 0.018m² (eg 150mm dia) and not more than 0.14m² (eg 375 x 375mm)
- Be free from even the slightest crack or source of leakage.
- Have no bends sharper than 45 degrees.
- Be entirely free of obstructions and swept by a qualified chimney sweep.
- Be connected only to the one appliance.
- Have a wall thickness of at least 100mm throughout its length, or be thoroughly insulated
- New masonry chimneys should be fitted with ceramic liners of at least 200mm diameter.
- Prefabricated chimneys should be fully insulated, of at least 150mm internal diameter, conform to BS4543 Part 2 and be installed in accordance with the manufacturer's instructions.

INSTALLATION CLEARANCES The stove must be placed on a solid non-combustible hearth conforming to building regulations. There must be no combustible material, including fuel, within: Rear 40cm, sides 30cm. If the Hi-Leg unit is fitted hearth temperature will not exceed 100°C, and light duty hearth material may be used.

LOAD BEARING Tiger is heavy - take care to ensure that the floor has adequate load-bearing capacity and consider fitting a load distributing plate if necessary

ASSEMBLY

STANDARD LEGS: Attach the legs if required. We suggest that the two legs with fixing holes be fitted to the back of the stove, for neater appearance. If the hearth is uneven, fit one or more washers between any leg and the stove body to lengthen it. Fix the stove down to the hearth, through the legs, using the screws and plugs provided.

'AMERICANA' COOKTOP KIT OPTION (supplied separately): Remove the two bolts located to the left and right inside the underneath of the standard top. Remove and discard the standard top, taking care not to damage the fibre seal. Fit the 'wings' to the cooktop and bolt the whole assembly back onto the stove body. Do not over tighten.

'EUROPA' HI-LEG KIT OPTION (supplied separately): Assemble the left, and right hi-legs *loosely* to the central bridging member. Attach to the underside of the stove using the bolts supplied before fully tightening. Note the 'Installation Clearances' on page 1. When used as a log store, logs must not be placed higher than the central 'bridging' member.

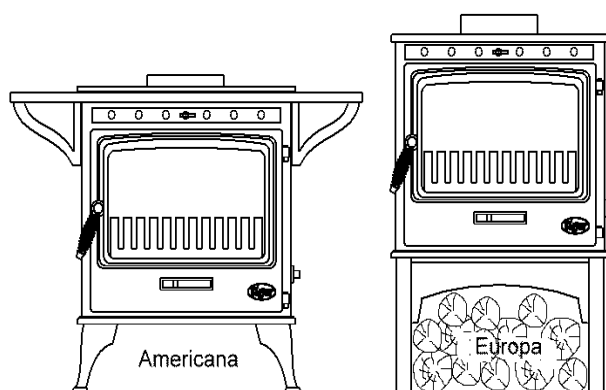

FITTING

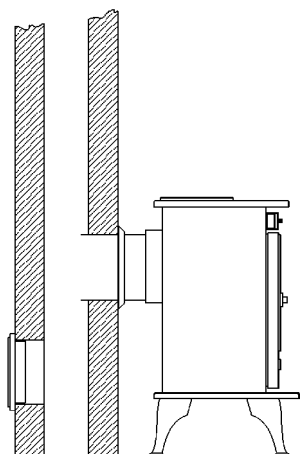

Rear flue connection into the chimney with sealing collar. Cleaning door on opposite side.

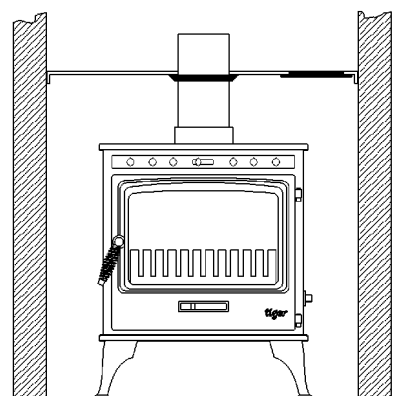

Top outlet through fully-sealed **steel** closure plate (fitted with cleaning door) into old, oversized, chimney with steel sealing collar.

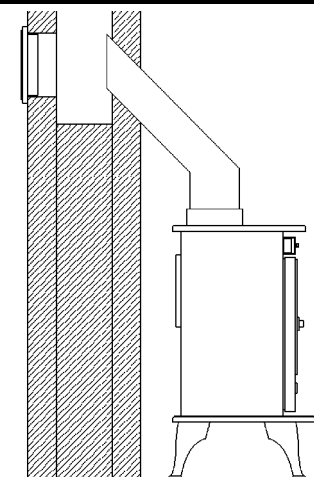

Top outlet with 45 degree bend sealed into masonry chimney with cleaning door on opposite side.

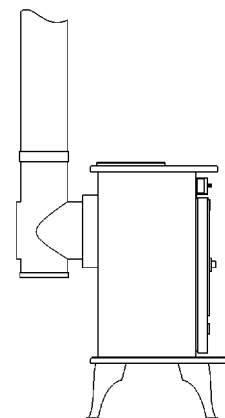

Rear outlet connected to top outlet by 'T' piece with cleaning door, to bring stove forward.

FLUE CONNECTION: Fasten the flue outlet and blanking plate to the top or back flue outlet with screws and nuts provided. Tiger can be connected to the chimney (using approved flue pipe components) in several ways, four of which are shown above. Whichever method is used it is imperative that: (1) The route for gases from the stove to the chimney terminal is completely air-tight-seal all joins with fireproof cement and/or heatproof rope. (2) It is possible to sweep the entire length- access doors may be required. (3) The entire construction is of durable fireproof materials- composite board is **not** a suitable material for closure plates, which should be of steel or concrete. Tiger should be secured to the hearth by bolting through the fixing holes drilled in the legs.

AIR SUPPLY Tiger needs air to breathe - there **must** be a **permanent** air supply into the room in which the fire is installed equal to at least 5.5cm² per kW heat output. While it is commonly accepted that this air for an appliance below about 5kW in an older (before c1980) property can often be supplied by air naturally leaking around windows etc, in any case of doubt fit a fixed air vent. An extractor fan, or another fireplace or heater can remove this air, even if fitted in a different room.

CO DETECTOR Carbon Monoxide is a poisonous gas, produced by this stove. It is wise to fit a CO alarm near the stove.

LIVING WITH A TIGER

LIGHTING Empty the ashes. Place two or three firelighters close together, or screwed-up paper covered with dry sticks, at the back of the grate and light them. When they are burning well gently fill the fire *very full* with dry fuel, close the door and set the air control slide to the 'high' (right) position. **To prevent castings from cracking, the first fire lit in your Tiger should be small- made with little fuel and the air slide set to 'low'.**

FILLING: When using mineral fuel, don't fill above the level of the lining bricks.

CONTROL How fast the fire burns depends on how much air reaches the fuel. The Tiger+ has two air controls, one above the window (the 'airwash control') and one below ('primary control'). Move the slides to the right for highest output, to the left for 'low'.

Our tests indicate highest efficiency on wood with the primary

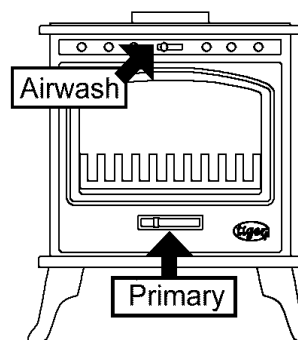

control all but closed and the airwash $\frac{2}{3}$ open. Anthracite works best with the airwash closed and the primary $\frac{1}{3}$ open. But the best settings will depend on your fuel, air supply and flue draught and can only be found from experience.

ECONOMY Surprisingly, best economy is achieved with the firebox very full and the air control set to 'low'. The fire will

burn much more efficiently than if you use 'little and often' and will need less frequent refuelling.

EMPTYING ASHES Operate the de-ashing mechanism by locating the operating tool onto the boss on the right-hand side of the stove and moving it backwards and forwards a few times. Use the tool to open the door and lift out the ashpan. Remember to let ash cool before disposing in plastic sacks or dustbins. There is no need to empty every last speck, but ash should never be allowed to build up so that it comes into contact with the underside of the grate.

EXTENDED BURNING Allow the fire to burn down to a low, hot firebed. Set the air control to 'low', empty the ash and fully fill with hard fuel such as anthracite (smaller sizes are to be preferred).

CLEANING Wipe the stove body with a slightly damp cloth when it is cool, don't use abrasives, metal polish or 'cream' cleansers as they can scratch the surface. Polished parts can be brightened using wire wool. Operating the stove for a few minutes at high output will usually burn-off any window deposits left by tarry or wet fuels. After a period of use tiny hairline cracks may appear on the window, this is not a fault and will not increase the risk of breakage but is a characteristic of the toughest and most heat-resistant material currently available.

OPENING THE DOOR Tiger is designed to be operated only with the door closed. Open the door slowly when refuelling or de-ashing to minimise fume emission.

FUELS

In certain areas you are required by law to burn smokeless fuels. Different fuels have **very** different burning characteristics - we strongly recommend that you try a selection of fuels (or mixtures) to find which suits you best.

WOOD (Not smokeless) When wood is cut down its cells are full of water. Burning such wet or 'green' wood wastes heat in making steam and produces flammable, acidic tars which will cling to, and can damage, your stove and chimney. Logs should be dried for at least a year (outside under a tarpaulin will do). When dry enough to burn, the ends will split. The fine, white residue produced when wood burns is not ash, but the remains of cell walls which can burn if kept hot enough, so don't de-ash the fire until absolutely necessary.

HOUSECOAL (or BITUMINOUS COAL) (Not smokeless) Is raw, natural coal. Inexpensive, easy to light and low in ash, it burns with great heat and an attractive flame. However, it makes lots of tarry smoke which will tend to stain the window and large volumes of flammable gas which make it difficult to control. Do not use housecoal.

COKE (Smokeless) Is natural coal from which the smoke has been removed (the smoke is distilled to make aspirin, creosote, ink and all sorts of useful things).

ANTHRACITE and WELSH DRY STEAM COAL (Smokeless) Are natural hard, shiny forms of coal. Though difficult to light, they burn with great heat and last a long time. Choose the 'small nuts' size.

PEAT (Legally smokeless in certain areas) Is natural semi-decomposed woody material. The nearly black moorland or bog peat should be dried and treated as for wood.

LIGNITE (Not smokeless) Is a natural mineral, between peat and coal. It lights easily and burns well, though some varieties produce excessive ash

BRIQUETTES Are compressed blocks of fuel, generally able to burn for long periods and remarkable for their consistency. 'Homefire' and 'Phurnacite' are smokeless types while other brands are made from lignite, peat or housecoal.

PETROLEUM COKE is made from oil waste. Easy to light and to control, its exceptional heat and lack of protective ash mean that it **MUST NOT** be used unless mixed with another fuel. Grate and firebar life will be drastically reduced when using petroleum coke

HOUSEHOLD WASTES Some plastics give off toxic fumes when burned and remember that batteries and aerosols explode! Tiger is not an incinerator, so only ever use the recommended fuels and **NEVER** use liquid fuels in any form

PROBLEMS?

Problems like those listed here are usually due to some difficulty with the installation, chimney or fuels, so please check back through this leaflet carefully.

POOR HEAT OUTPUT Tiger is sufficient to heat a typical room of up to 100m³. The actual size depends on the insulation and air-change ratio of the room. To attempt to heat a larger room will result in excessive fuel consumption. Use only the recommended fuels. If necessary seek specialist advice.

LACK OF CONTROLLABILITY Some fuels give off lots of very flammable gas when they get hot. Wood may burn excessively until the gases have been used up. You can reduce this effect by making sure that the fire is set to 'low' for a while before refuelling and checking that the door seals fully.

WINDOW GETS VERY DIRTY Extended use at low output can cause stains on the window, which usually disappear when the stove is used on 'high' with the airwash fully open. Reduce the risk of stains by using only very dry fuel.

DIFFICULTY BURNING FOR EXTENDED PERIODS If the fire goes out with fuel still in the firebox, then this is probably because too little air has been reaching it, try leaving the air control open a little more. Check that the door seals are sound and that there are no cracks or gaps anywhere in the flue. For longest burning, we recommend hard fuels such as anthracite.

SMOKE COMING INTO ROOM Fumes are poisonous-smoke emission must not be tolerated. Causes might be:

- **INADEQUATE SEALS:** Check that the flue is fully sealed to the appliance and throughout its entire length. Even the tiniest crack or gap can spoil the draught.
- **UNSUITABLE, BLOCKED OR UN-SWEPT CHIMNEY:** The first requirement for correct operation is a sound chimney. Check the requirements earlier in this document and in any case of doubt have the chimney professionally swept.
- **POOR AIR SUPPLY:** Lack of air to the fire will cause smoking and poor performance. Air supply problems may be worse in certain wind conditions (often incorrectly ascribed to 'downdraught', which is in fact very rare), where air can be sucked out of the room. Fit an air vent, as near to the fire as possible, facing into the usual wind direction.
- **DOWNDRAUGHT:** Wind can blow *down* a chimney if there is something higher nearby such as a tree, hill or high building. This can be cured by fitting an anti-downdraught cowl to the chimney top.

CHIMNEY FIRES: In the rare event of a chimney fire - usually identified by a roaring sound and dense clouds of black smoke and sparks exiting the top of the chimney - immediately close the door of your 350, shut all the air controls and call the fire brigade. Prevent fires by having your chimney swept at least annually, or more often if smoky fuels are used.

MAINTENANCE

MONTHLY- CLEAN THE THROAT PLATE and CHECK THE DOOR SEALS The throat plate (sometimes called a baffle plate) is the cast-iron plate inside the roof of the stove, item (9) in the diagram below. It serves to distribute flames towards the sides and top of the fire and so increase heat output. Remove the plate when the stove is cool to brush off any deposits of soot or ash which might cause a blocked chimney. Check that the door seals are undamaged, (replacing them if necessary) and that they fully seal against the stove body. After a period of use the seals can become compressed - if this happens, open the door and lift it upwards to remove, screw in the hinge supports on the stove body and re-fit the door, repeating this until a tight seal is achieved. The door catch can be adjusted by unfastening the nut on the back of it and placing washers either in front of or behind the catch itself to move it in or out.

ANNUALLY- SWEEP THE CHIMNEY The entire length of the chimney from stove to outlet should be swept annually, or more often if smoky fuels are used.

REFURBISHMENT Should the stove body become scratched or dull, repaint it only with heat resistant paint supplied for the purpose and only when the fire is completely cold. A small jar of paint is supplied with the stove.

NEW PARTS Tiger has been extensively tested for safety - please don't try to modify it and always make sure to obtain *genuine* spare parts.

SPARE PARTS

TIG5-1 PLUS Main casing

TIG5-4 Main casing Base

TIG5-6 Main casing Top

TIG5-7 Flue outlet collar

TIG5-8 Flue outlet blank

TIG5-9 Throat plate

TIG5-10 Grate frame

TIG5-11 Front firebar

TIG5-12 Grate

TIG5-14 Door

TIG5-15 Primary air slide

TIG5-16 Airwash plate

TIG5-17 Door inner plate

TIG5-18 Hinge and pin

TIG5-19 Ashpan

TIG5-20 Window

TIG5-21 Glass rope - large

TIG5-22 Glass rope - small

TIG5-23 Door catch assembly

TIG5-24 Operating tool

TIG5-25 Leg

TIG5-26 Brick - rear

TIG5-27 Brick - side left or right

TIG5-28 Fire cement

TIG5-29 Stove black paint

TIG5-30 Screws and fixings pack

TIG5-31 Spiral wire handle- black or silver

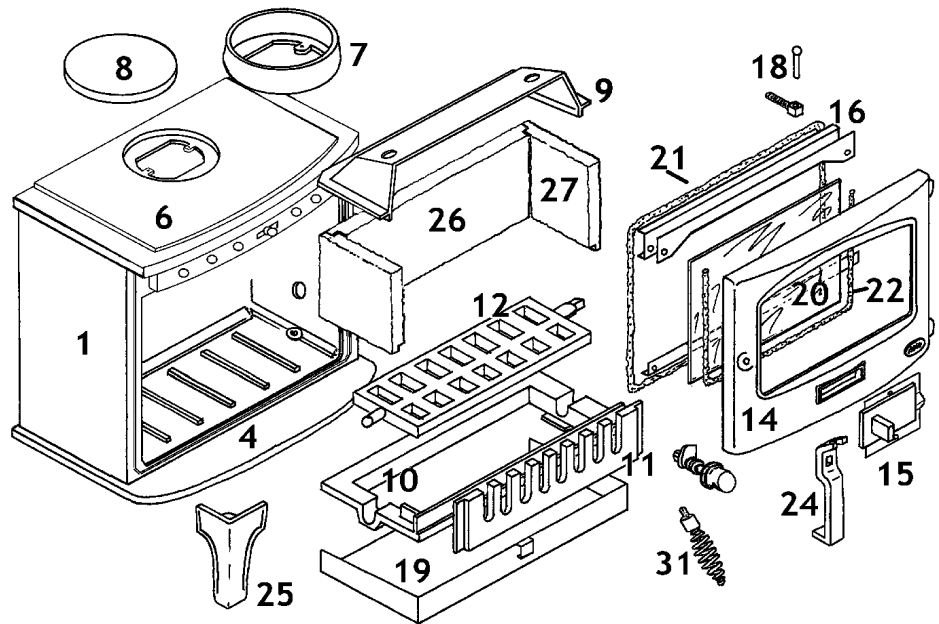

The Tiger stove is fully guaranteed for one year from the date of purchase, in addition to your statutory rights.



www.tiger-stoves.com

Distributed in Europe by:

Capital Fireplaces, Unit 12, Henlow Ind Est, Henlow
Camp, Beds SG16 6DS UK
Tel: 01462-813138

Percy Doughty & Co, Imperial Point, Stone Hill Rd,
Farnworth Bolton BL4 9TN UK
Tel: 01204-868-550